

## SafeStore Birkdale Plus Secure Storage Unit

- \* Size: 1524mm (5ft) wide x 3300mm (10ft 11in) deep \* Colours available: Green, Dark Grey or Ivory
- \* Standard accessories: timber floor, universal ramp, shelves and hooks/hook rail.
- \* Additional accessories available: tool rail, hanging bike racks and single and double bike stands, heavy duty ladder and tool rack, LED sensor lights (240mm or 600mm)



### External Dimensions

Weight:  
334kg (52.5 stone)  
Door Aperture:  
1690mm (5ft 6") x  
1420mm (4ft 7")

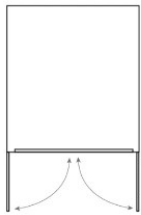

Door Clearance  
760mm (2ft 6")

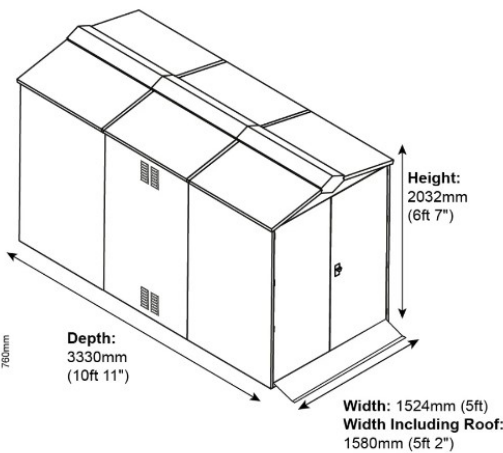

### Internal Dimensions

A. Internal Height (to apex):  
1950mm (6ft 4")  
B. Internal Height (to eaves):  
1760mm (5ft 9")  
C. Internal Depth:  
3222mm (10ft 7")  
D. Internal Width:  
1460mm (4ft 9")

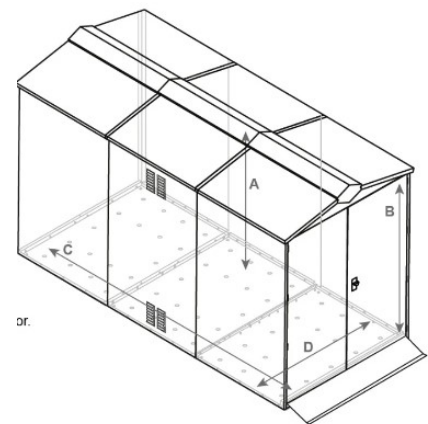

- \* 10 year warranty
- \* Steel-plated lock
- \* Reinforced panels
- \* 334kg in weight (52.5 stone)
- \* 5 point locking system
- \* Large easy access double doors
- \* Designed and made in the UK
- \* Welded hinges
- \* Shed air vent system